

# technical specification sheet

## Series T90

	Load Cell Capacity		Units
	500, 1000, 2000	3500, 5000, 7500	kg
Rated Output	2	2	mV/V $\pm$ 0.25%
Combined Error	< $\pm$ 0.05	< $\pm$ 0.05	%*
Non-repeatability	< $\pm$ 0.025	< $\pm$ 0.025	%*
Creep (30 minutes)	< $\pm$ 0.05	< $\pm$ 0.05	%*
Temperature Effect on Zero Balance	< $\pm$ 0.0025	< $\pm$ 0.0025	%*/ $^{\circ}$ C
Temperature Effect on Span	< $\pm$ 0.008	< $\pm$ 0.008	%*/ $^{\circ}$ C
Compensated Temperature Range	-10 to +40	-10 to +40	$^{\circ}$ C
Operating Temperature Range	-40 to +80	-40 to +80	$^{\circ}$ C
Safe Overload	150	150	%*
Ultimate Overload	300	300	%*
Zero Balance	< $\pm$ 1	< $\pm$ 1	%*
Input Resistance	380	380	$\Omega$ $\pm$ 30
Output Resistance	350	350	$\Omega$ $\pm$ 1.5
Insulation Resistance	>5000	>5000	M $\Omega$ @ 100V
Recommended Supply Voltage	10	10	V
Maximum Supply Voltage	15	15	V
Environmental Protection	IP 67		-

\*With respect to rated output

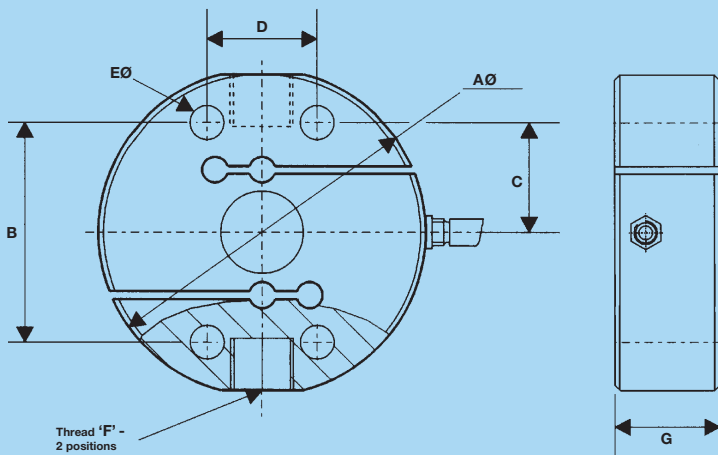

Capacity (kg)	A $\emptyset$	B	C	D	E $\emptyset$	F	G
500	125	84	42	42	13	M16 x 2	40
1000, 2000	125	84	42	42	13	M24 x 2	40
3500, 5000, 7500	125	84	42	42	13	M24 x 2	40

All dimensions in mm.

### Electrical Connections

Via 4 core, 4m, 6mm diameter screened polyurethane cable.

Screen not connected electrically to load cell.

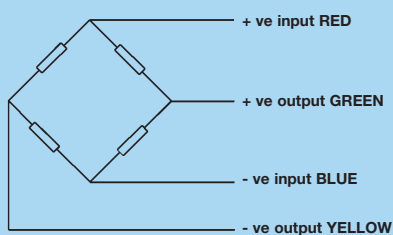

### Shipping Weights: (kg)

500, Cell = 3  
1000-7500, Cell = 3.6

### Construction

Load Cell manufactured from alloy steel.

### Options

M16 conduit adaptor for connecting additional cable protection.

Our policy is one of continuous product enhancement. We therefore reserve the right to incorporate technical modifications without prior notification.

Distributed by

**Thames Side - Maywood**

Thames Side-Maywood Limited

17 Stadium Way, Reading

Berkshire RG30 6BX UK

Tel: +44(0)118 9458200

Fax: +44(0)118 9458225

E-mail: sales@thames-side.co.uk

Web: www.thames-side-maywood.com

HALMA  
GROUP  
COMPANY



Approval No. 925394

# Series T90

**Folded shear beam load cell for  
hopper, tank & vessel weighing**  
*capacities 500 kg to 7,500 kg*



alloy steel load sensor

bi-directional

sealed to IP 67

1 year warranty

suitable for use in tension

corrosion resistant

mounting accessories available

unique folded shear beam design

This unique folded shear beam load cell is manufactured from high quality tool steel.

A comprehensive range of capacities is available in one body size.

The cell is designed for hopper, tank and vessel weighing and is very simple to install.

**Thames Side - Maywood**

...your specialist load cell partner