

# Series VC3500

## Load cell assembly for tank and vessel weighing

capacities 2t to 200t

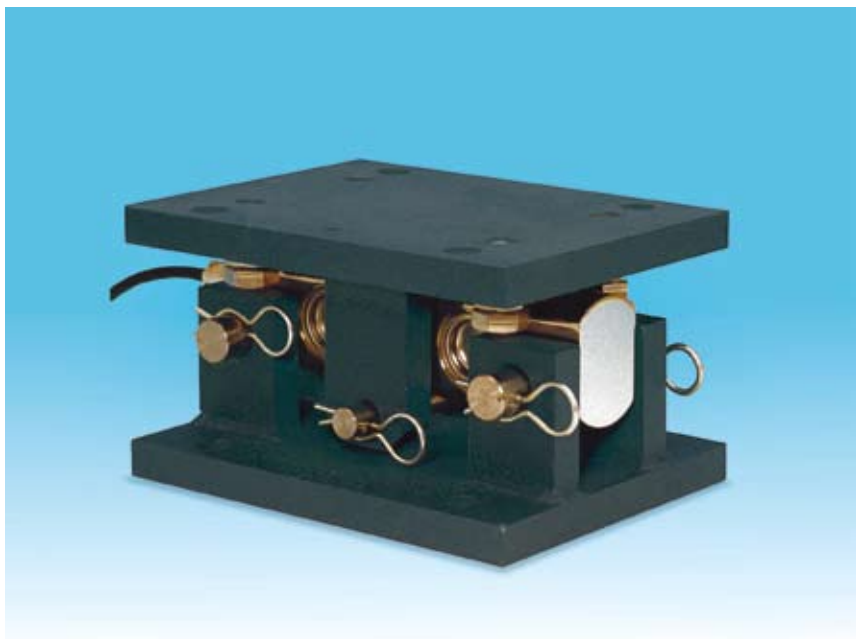

<b>Stainless steel load sensor</b>	<b>Fully welded construction IP68</b>
<b>Optional 4-20mA output</b>	<b>Resistant to off-axis loading</b>
<b>Low profile</b>	<b>5 year warranty</b>
<b>Integral lift off prevention</b>	<b>Allows vessel expansion/contraction</b>
<b>High durability mud and chemical resistant cable</b>	<b>Optional stainless steel or galvanised alloy steel loading assembly</b>

Vessel weighing problems solved simply and cost effectively. The VC3500 incorporates lift off prevention and, on most capacities, holding bolts to assist with routine maintenance. The VC3500 is also available with intrinsically safe certification ATEX EEx ia IIC T6 for use in both Gas and Dust Zones and Ex nA II T6 Gas only certification for use in Zone 2 applications without safety barriers.

# Series VC3500

The VC3500 family of load cells are available in capacities ranging from 2,000kg to 200,000kg. They are especially suitable for high capacity vessel weighing and feature a combined error specification of  $< \pm 0.03\%$

The critical sensor element of the VC3500 unit is a fully welded double ended shear beam, manufactured from high tensile 17-4 PH released stainless steel, heat treated to give a high ultimate tensile strength. This treatment provides an extremely stable platform for the strain gauges. In common with all Thames Side load cells, the strain gauged element is temperature compensated to ensure accuracy is maintained through a wide temperature range.

Stainless steel diaphragms are TIG welded in position to provide total environmental sealing. This method of construction allows Thames Side to offer a five year warranty on the complete unit.

## Vessel Restraints

The loading assembly is an integral part of the VC3500 and in many cases can eliminate the requirement for vessel restraints or check rods.

## Atex Certification

The VC3500 has ATEX EEx ia IIC T6 certification for both dust and gas in all zones, as well as Ex nA II T6 gas only certification which allows zone 2 use without safety barriers.

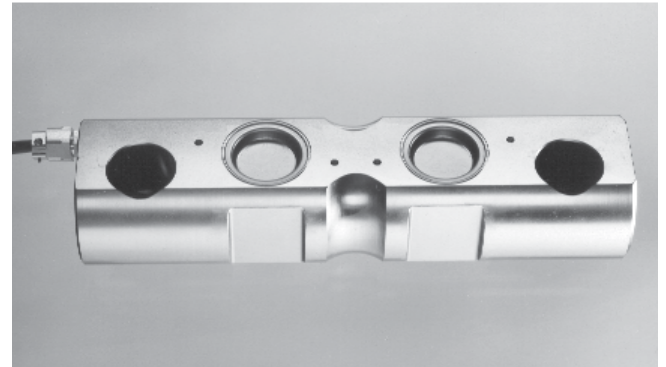

## High Temperature

The VC3500 range is available in a high temperature variant which utilises special load cell components and PTFE Teflon cable for operation in environments up to 150°C.

## Environmental Protection

Although the standard load cell is manufactured from stainless steel and sealed to IP68, special parylene coating of the load cell is available as an option to provide additional protection in extreme environments where stress corrosion could occur.

## Amplified Output

An integral 4-20mA amplified output can be specified where required.

## INSTALLATION DETAILS

**CABLE LENGTH:** 20 metres

**NOTE:** No holding bolt facilities on 100t, 150t and 200t capacities.

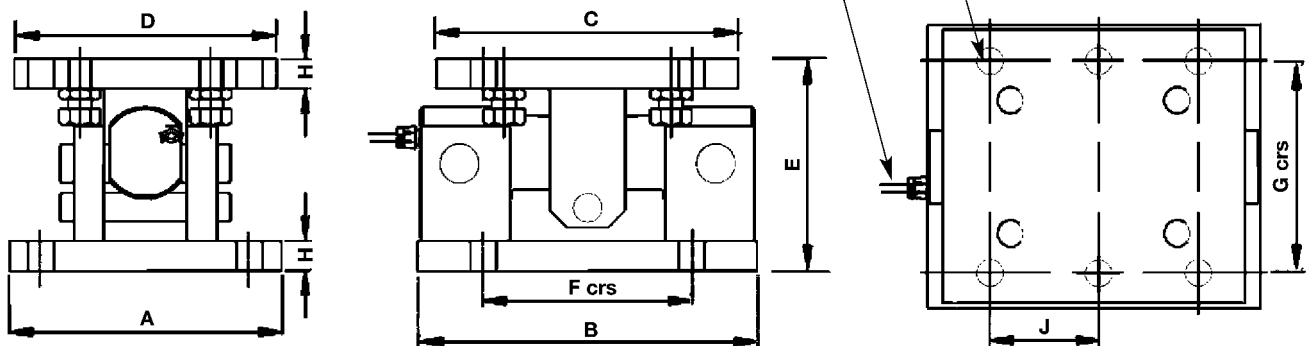

Range t	A	B	C	D	E	F	G	H	J	K	L
2, 5, 10, 15, 20	177.0	235.0	235.0	177.0	135.0	155.0 crs	140.0 crs	18.0	N/A	8	18.0ø
30, 50	254.0	285.0	254.0	220.0	210.0	175.0 crs	175.0 crs	25.0	N/A	8	22.0ø
75	254.0	330.0	330.0	254.0	250.0	200.0 crs	180.0 crs	25.0	100.0 crs	12	22.0ø
100	350.0	440.0	440.0	340.0	275.0	300.0 crs	235.0 crs	30.0	150.0 crs	12	26.0ø
150,200	350.0	440.0	440.0	350.0	325.0	310.0 crs	285.0 crs	30.0	155.0 crs	12	32.0ø

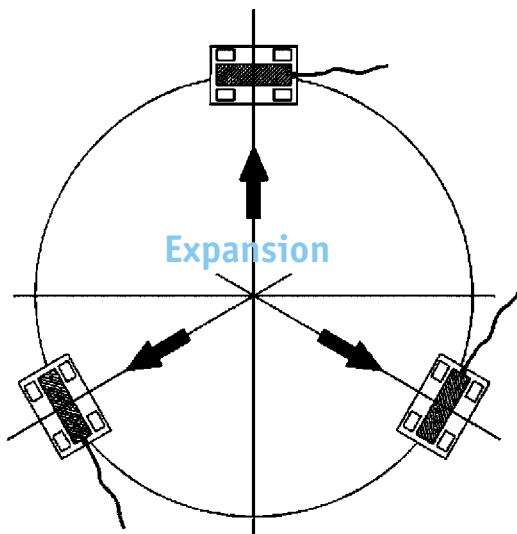

VC3500 3 x load cell installation

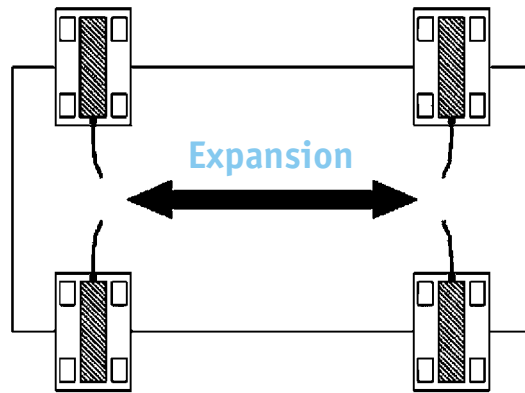

VC3500 4 x load cell installation

## ASSEMBLY DEFLECTION AND EXPANSION

Capacity t	Deflection mm	Expansion across load cell assembly
2, 5	0.20	± 5mm
10	0.25	± 5mm
15	0.30	± 5mm
20	0.40	± 5mm
30	0.50	± 9mm
50	0.50	± 9mm
75	0.80	± 9mm
100	0.80	± 12mm
150/200	0.90	± 12mm

Due to the unique design of the VC3500, Transverse and Non Axial misalignment errors are minimised.

### VC3500 Capacities 2 - 200 t

The unit is manufactured in 5 shell sizes as follows:

Shell size 1 : 2 - 20 t

Shell size 2 : 30 - 50 t

Shell size 3 : 75 t

Shell size 4 : 100 t

Shell size 5 : 150 - 200 t

The loading assembly has a tough, durable, paint finish as standard to provide the highest level of protection. Stainless steel or galvanised alloy steel is available as an option.

The bi-directional freedom of movement of the top plate allows for a high degree of mis-alignment in the structure, particularly important in large structures where dimensional accuracy, rigidity and angular conformity cannot be guaranteed, or where large changes in ambient temperature are anticipated. The complete assembly incorporates built in lift off protection, reducing the need in many cases for additional restraints. Integrated holding bolts on capacities up to 75t facilitate routine maintenance. This eliminates the need for expensive installation work, giving a very cost effective total solution.

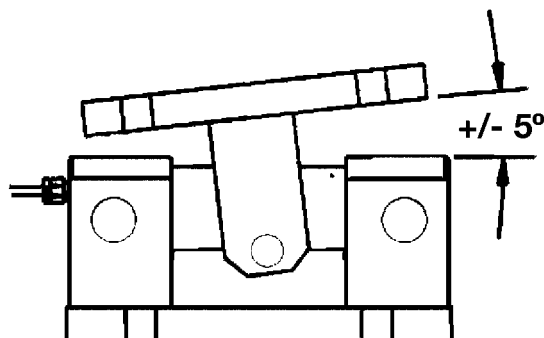
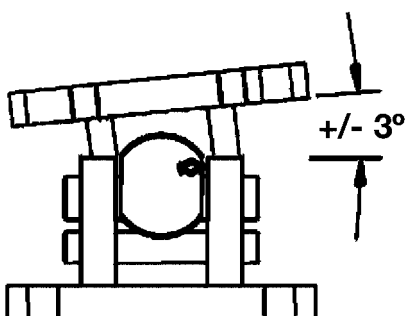

# technical specification sheet

## Series VC3500

		Units
Standard Load Ranges	2, 5, 10, 15, 20, 30	
	50, 75, 100, 150 & 200	t
Full Load Output	2.0(+/- 0.25%)	mV/V
Excitation Recommended	10	V
Excitation Maximum	18	V
Safe Service Load	150	%
Ultimate Load	300	%
Maximum Lift Off	30	%
Combined Error	<+/- 0.03	%
Repeatability	<+/- 0.015	%
Output at Zero Load	<+/- 2.0	%
Input Resistance	785 +/- 20	ohms
Output Resistance	700 +/- 5	ohms
Operational Temperature Range	-50 to +80	C
Compensated Temperature Range	-10 to +40	C
Temperature Coefficient on Zero	<+/- 0.002	%/C
Temperature Coefficient on Span	<+/- 0.0012	%/C
Environmental Protection	IP68	
Insulation	>500 at 100Vdc	M ohms

All percentages are related to Full Rated Load

### Mechanical Interface

via 8 off attachment holes (2-50t)  
12 off attachment holes (75-200t)

### Construction

Sensor element High strength stainless steel type 17-4PH  
Mounting assembly Alloy steel, durable painted finish. Galvanised and stainless steel available as options.  
Shafts Corrosion resisting hardened stainless steel

### Electrical Connections

4 Core 16 / 0.2 mm, screened polyurethane mud resistant cable.  
Cable length 20m

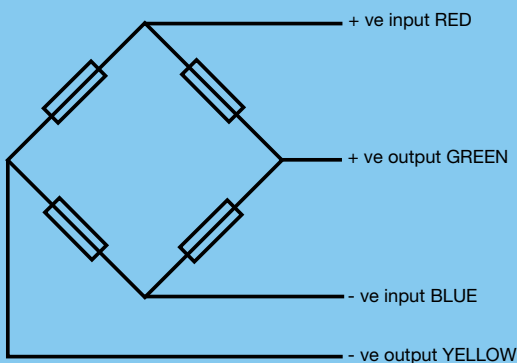

Our policy is one of continuous product enhancement. We therefore reserve the right to incorporate technical modifications without prior notification.

Distributed by



### Thames Side Sensors Ltd

Unit 10, io Trade Centre, Deacon Way,  
Reading, Berkshire RG30 6AZ  
tel: +44 (0) 118 941 1387 fax: +44 (0) 118 941 2004  
e-mail: sales@thames-side.co.uk  
web: www.thames-side.com